

DIRECTLED – LED Area Light with Intelligent Sensors - AL-8510 Series

FEATURES & SPECIFICATION SHEET



Application

The LED Area Light with Intelligent Sensors, Series AL-8510 (also available without Intelligent Sensors Series AL-8500), is designed to replace High Pressure Sodium (HPS), Metal Halide (MHL), High Intensity Discharge (HID) and Compact Fluorescent (CFL) lamps.

Suitable for use in Area Lighting, Parking Lots, Street Lighting, Roadway, Shoe Box Fixtures and much more.

Features

- 3-in-1 Dimming
- 150 Lumens/Watt
- Microwave Sensor
- Photocell Sensor
- Wi-Fi Sensor

LED PCB & Driver

A long lifecycle rating of 50,000 hours

Warranty

Lamp is guaranteed for 5 years against manufacturing defects.

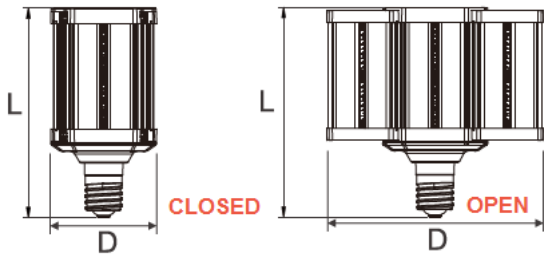
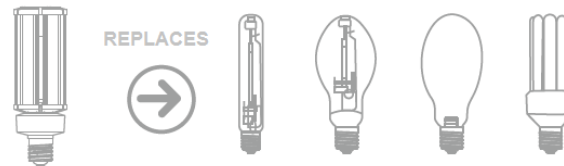

AL-8500/8510 110W

HID400W

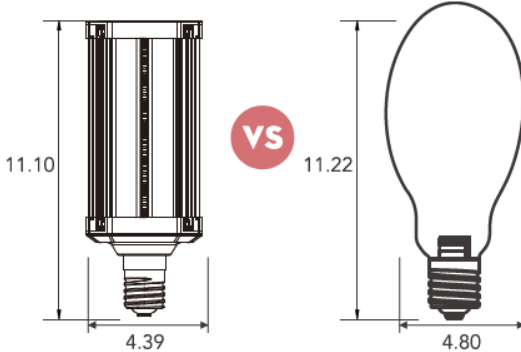

Ordering Information

AL-8510 - 110 - 5K

Model	Watts	Color
AL-8510	110w	5000k

MODEL	WATTS	*COLOR TEMP	VOLTS U = 120-277v	BASE	LUMENS	REPLACES (HPS MHL HID)	DIMENSIONS CLOSED/OPEN E39 (L x D)
AL-8510	80w	5000k	U	E39	12000lm	250w	4.37"/9.02" x 8.70"
AL-8510	110w	5000k	U	E39	16500lm	400w	4.37"/9.02" x 8.70"

(*Available Color Temp Range 3000k – 6500k on request.)