

# DIRECTLED – HBA1 Induction High / Low Bay Light Fixture

## FEATURES & SPECIFICATION SHEET

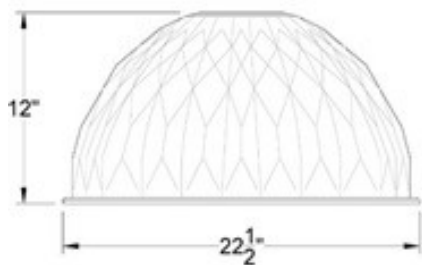
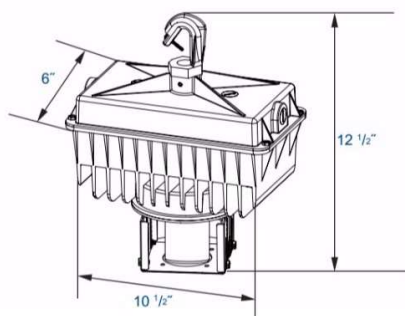

### Application

The HBA1 series aluminum high / low bay fixture is an ideal choice for replacement of common High Pressure Sodium and Metal Halide Garage fixtures. The electronic ballast features a high >0.98 power factor for cool, efficient, flicker-free operation.

Common applications include: service hallways, parking garages, loading docks, stairwells, utility closets, gas stations, shopping malls, even certain retail and wholesale applications.

### Features

- 16" or 22" Faceted Aluminum Reflector with Die Cast Aluminum ballast casing, and white powder coated finish for superior corrosion resistance
- Optional lenses and accessories available and sold separately
- IP20 Rated

### Lamp & Ballast

A long lifecycle rating of 100,000 hours

### Warranty

Lamp and ballast guaranteed for 5 years against manufacturing defects.

MODEL	WATTS	*COLOR TEMP	VOLTS U = 120-277v	RETROFIT WATTS	LUMENS	DIMENSIONS (W x L)
HBA180	80w	5000k	U	160W	6500Lms	24.5" x 22.5"
HBA1100	100w	5000k	U	200W	8100Lms	24.5" x 22.5"
HBA1120	120w	5000k	U	250W	9600Lms	24.5" x 22.5"
HBA1150	150w	5000k	U	300W	1200Lms	24.5" x 22.5"
HBA1200	200w	5000k	U	400W	16500Lms	24.5" x 22.5"
HBA1250	250w	5000k	U	500W	21750Lms	24.5" x 22.5"