

# DIRECTLED BLE PL Plug-In Retrofit Lamp

## FEATURES & SPECIFICATION SHEET

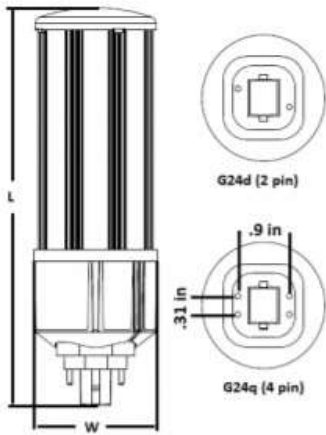

### Application

The BLE PL Series LED retrofit lamp, is specifically designed to replace HID, MH, and CFL lamps in existing light fixtures providing 60-90 percent in energy savings.

### Features

- 360° beam angle, GX24d 2-pin or GX24q 4-pin Base
- Direct to AC (Direct Wire) connection or Ballast Compatible (Plug & Play)
- 120Lm/Watt LED Array
- Designed for use in open or enclosed fixtures
- Durable Aluminum Construction
- Compact Design
- IP64 Rated
- UL Listed

### LED PCB & Driver

A long lifecycle rating of 50,000 hours

### Warranty

Lamp is guaranteed for 5 years against manufacturing defects.

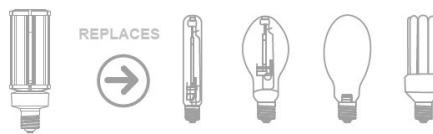

#### Ordering Information

**BLEPL7 - 5K - G24d**

Model	Color	Base
-------	-------	------

MODEL	*COLOR TEMP	BASE d = 2 Pin q = 4 P	DRIVER U = 120 – 277V	WATTS	LUMENS	REPLACES (HPS MHL HID)	DIMENSIONS (E26/E39 & EX39 L x W)
BLEPL5	5000k	G24d / G24q	U	5w	600Lms	11w	4.8" x 1.77"
BLEPL7	5000k	G24d / G24q	U	7w	840Lms	13w	4.8" x 1.77"
BLEPL9	5000k	G24d / G24q	U	9w	1080Lms	18w	5.4" x 1.77"
BLEPL12	5000k	G24d / G24q	U	12w	1440Lms	26w	6.2" x 1.77"
BLEPL15	5000k	G24d / G24q	U	15w	1530Lms	32w	6.1" x 2.17"
BLEPL20	5000k	G24d / G24q	U	20w	2400Lms	42w	6.9" x 2.17"

(\*Available Color Temp Range 3000k – 6500k (Warm to Cool) on request.)